

XX. *Measurements of Specific Inductive Capacity of Dielectrics, in the Physical Laboratory of the University of Glasgow.* By JOHN C. GIBSON, M.A., and THOMAS BARCLAY, M.A. Communicated by Sir WILLIAM THOMSON, F.R.S.

Received November 23, 1870,—Read February 2, 1871.

THE object of this paper is to describe the instruments and processes employed in a series of experiments on the specific inductive capacity of paraffine, and the effect upon it of variations of temperature.

The chief instruments employed in this investigation were the Quadrant Electrometer, and two others which will now be described.

I. The Platymeter, so named by suggestion of the late Dr. WHEWELL from its use in the comparison of electrostatic capacities, was, in a rudimentary form, shown to the Mathematical and Physical Section of the British Association at its Glasgow Meeting in 1855, by Sir WILLIAM THOMSON. It consists of two condensers of equal capacity, each of which has one of its opposed surfaces in metallic connexion with the corresponding surface in the other.

In the instrument employed (see Plate XLIII. fig. 1) the conductor constituting these two connected surfaces is a brass cylinder (*c c*) 22·94 centimetres in length and 5·1 centimetres in diameter, supported at its ends in a horizontal position by two vulcanite stems (*d d, d d*). Round it are placed two equal and similar pieces of brass tubing (*p p, p' p'*), 7·68 centimetres in length and 8·6 centimetres in diameter, each supported by a vulcanite stem (*e e, e e*), so as to be concentric with the cylinder and at equal distances from its ends. The four supports (*d d, d d, e e, e e*) are fixed in a massive plate of iron (*i i*); and the whole is enclosed in a stout metal box (*m m, m m*), an electrode (*n n*) from the inner cylinder being carried through an insulating plug (*o*) of paraffine in the end of the box, and another (*q q, q q*) from each of the tubes through similar plugs (*r r*) in the top of it. By this means shreds and dust are excluded, and paraffine is found to be so good an insulator that no inconvenience is experienced by employing it in this way.

II. The Sliding Condenser is a condenser the capacity of which may be varied by altering the effective area of the opposed surfaces. The following form of this instrument was employed (see fig. 2). Two pieces of brass tubing (*a a, b b*), 2·48 centimetres in diameter and 26·58 and 35·3 centimetres in length respectively, are supported end to end upon vulcanite stems (*c c, d d*) securely fixed in a massive iron plate (*h h*). Within these tubes, and coaxially with them, moves a brass cylinder (*e e*) 36·6 centimetres in length and 1·15 centimetre in diameter, supported at one end upon four brass feet (*f, f*) which slide on the inner surface of the longer tube, and loaded at that end so as to rest

stably upon them. Attached to this cylinder is a vertical arm ( $g$ ) which projects through a slot extending along the upper part of the surrounding tube. This arm carries an index ( $i$ ) by which the position of the sliding cylinder or core is indicated on an attached scale ( $k k$ ). This scale is 22.86 centimetres long, and is divided into 360 divisions, each  $\frac{1}{40}$  of an inch in length. The tube ( $b b$ ) which supports these parts of the instrument, though placed on vulcanite stems for convenience in testing, is in working kept in connexion with the earth. The other ( $a a$ ), which may therefore be called the insulated tube, is closely surrounded by a sheet of metal ( $l l$ ), which is securely fastened to the iron base of the instrument. This sheet, being connected with the earth, guards the insulated tube against electric disturbance, and adds largely to the capacity of the condenser. As an additional security against disturbance, another sheet of metal ( $m m$ ) is fastened round the former at some distance from it.

In using these instruments the following connexions are made (see Plate XLIV. fig. 3).

The inner cylinder or core ( $c c$ ) of the platymeter is connected with two ( $q, q''$ ) of the quadrants of the electrometer, the other two ( $q', q'''$ ) being connected with the case of the electrometer ( $n n n$ ) and with the earth. The condenser to be measured is connected with one of the tubes or sides of the platymeter, and the insulated tube of the sliding condenser with the other. All other parts of the sliding condenser and the box and base-plate of the platymeter are kept in metallic communication with one another, and with the disinsulated pair of quadrants of the electrometer.

Now suppose the two sides ( $p$  and  $p'$ ) of the platymeter to be exactly equal, and the condensers to be compared, say A and B, also equal. Let the insulated quadrants ( $q, q''$ ) be temporarily connected with the disinsulated pair ( $q', q'''$ ), and let the condenser A, together with  $p$ , the side of the platymeter with which it is connected, receive a positive charge. Then  $c$ , the core of the platymeter, becomes by induction negatively electrified. The earth-connexion of the quadrants ( $q, q''$ ) is now broken, and the charge thus insulated upon  $c$  remains masked by the action of  $p$  so as to cause no deflection of the needle. A connexion is now established between  $p$  and  $p'$ , the two sides of the platymeter, so that on the supposition of equality already made, the charge is now distributed over a system of double capacity, and the potential of the whole becomes half of that of A and  $p$  before distribution. Both sides of the platymeter are now acting upon  $c$ , each with half the original intensity of  $p$ , so that the resulting effect upon the core being unaltered, no deflection of the needle takes place.

If the condenser A be of greater capacity than the condenser B, then, on connecting  $p$  and  $p'$ , the capacity of the whole charged system is less than double that of A and  $p$ , and its potential, therefore, greater than half the original potential of A and  $p$ . Each side of the platymeter, therefore, is now acting with more than half the original intensity of  $p$ . The result is an increased action on the core of the platymeter, and the consequent liberation of positive electricity to act on the needle, which, in the ordinary arrangement of the electrometer, is deflected to the right.

If, on the other hand, the capacity of the condenser A be less than that of the con-

denser B, the potential of the system after the distribution of the charge is less than half the original potential of A and  $p$ . The combined action of the two sides  $p$  and  $p'$  is now less than the original action of the one side  $p$ . Negative electricity is thus set free, and this, acting on the needle, deflects it to the left.

If B be the charged condenser, or if A be charged negatively, the effect in the last two cases will be reversed. If both the condensers be charged, one positively and the other negatively, the effect will be greater in degree, but precisely similar in kind. This is the method usually adopted, as it gives more marked indications without increasing the risk of failure of insulation.

In measuring any condenser by comparing it in this way with the sliding condenser, the latter is, in accordance with the indications thus given by the electrometer, so adjusted that its capacity becomes equal to that of the condenser to be measured.

In order to find from this the true value of the measured condenser, it is necessary to know the value of the sliding condenser in scale-divisions when its index is at zero on the scale.

For this purpose a condenser was employed of such a form that its capacity could be very accurately determined in absolute measure\* (see fig. 4). This consists of two metallic spheres of different diameters placed one within the other. The outer consists of two brass hemispheres ( $aa, a'a'$ ), having their inner surfaces accurately turned, and having projecting flanges which are firmly fastened together by three brass screws (one of which is shown at  $c$ ). In the top of the upper hemisphere is a small hole through which projects an electrode ( $dd$ ) from the inner sphere ( $bb$ ), which rests upon three vulcanite pins (one of which is shown at  $e$ ), so as to present an accurately spherical surface truly concentric with the inner surface of the outer sphere.

In order to determine in absolute measure the electrostatic capacity of this condenser, its dimensions were carefully ascertained in the following manner. The quantity of water contained by the outer sphere was measured, and found to be 7394.8 grains at temperature  $15^{\circ}5$  Centigrade, or 479.66 cubic centimetres, which, with the necessary correction for the vulcanite pins, .287 cubic centimetre, gave as the radius 4.857 centimetres. The radius of the inner sphere was obtained from the content of the outer sphere and that of the space between the two spherical surfaces. Of the content of this space five determinations were taken. These are shown in the following Table. The values in the second column include the correction for the volume of the vulcanite pins.

Grains at $15^{\circ}5$ C.	Cubic centimetres.
1465	95.313
1467	95.443
1471	95.702
1469	95.573
1468.5	95.540

\* The absolute unit of electrostatic capacity referred to in this paper is the capacity of an insulated spherical conductor of one centimetre radius placed at an infinite distance from all external objects.

The mean of these values, and the previously measured volume of the containing spherical surface, give 4.5107 centimetres as the radius of the inner sphere.

The capacity of a spherical condenser is calculated by the formula

$$\text{Capacity} = \frac{r r'}{r' - r},$$

where  $r'$  is the radius of the outer, and  $r$  the radius of the inner sphere.

In this case  $r' = 4.857$  centimetres and  $r = 4.5107$  centimetres. Hence the capacity is equal to 63.264 centimetres. The specific inductive capacity of the vulcanite of the pins which support the inner sphere being greater than that of air, causes an increase of the whole capacity of about .19 centimetre. The hole in the top causes a diminution of .085 centimetre, and the electrode passing through it an increase of .15 centimetre. The actual value of the condenser is therefore 63.519 centimetres.

To reduce this to scale-divisions of the sliding condenser, the value of one division in absolute measure is calculated by the formula for a cylindrical condenser,

$$\text{Capacity} = \frac{1}{2} \cdot \frac{l}{\log \frac{r'}{r}},$$

where  $r'$  is the radius of the outer surface,  $r$  the radius of the inner surface, and  $l$  the length of the condenser whose capacity is to be calculated.

In this case  $r' = 2.4837$  centimetres,  $r = 1.1515$  centimetre, and  $l = \frac{1}{40}$  of an inch or .063499 centimetre. Here  $r'$  was determined from a measurement of the volume of water contained by the tube, the length of which was accurately measured. To determine  $r$ , the circumference of the core was measured by winding fine wire round it, and measuring the length of a certain number of turns, the necessary corrections being made for the thickness of the wire and its spiral arrangement. The value for electrostatic capacity of one scale-division is therefore .0413 centimetre; and hence the spherical condenser is equal in capacity to 1538 scale-divisions.

[Direct electrical measurements taken subsequently on a sliding condenser of greater range gave 1607 scale-divisions as the value of the spherical condenser. This is probably greater than the actual value, while that derived from calculation is too small by a quantity due to the action of parts whose capacity could not be numerically determined. The mean of these values, 1572 scale-divisions, may therefore be taken as the value of this condenser.]

When the capacity of the spherical condenser was measured electrically while in connexion with the side  $p$  of the platymeter, the reading obtained on the scale of the sliding condenser was 211. When the connexions were reversed, that is, when the spherical condenser was connected with the side  $p'$  of the platymeter, the reading obtained was 183. The difference of the two readings thus obtained shows some inequality of the sides of the platymeter.

Now to find the true reading in any case from two such readings, suppose the side  $p$  to be equal to  $n \times p'$ . If no deflection of the needle takes place on the distribution of

the charge, this can only arise from the action of the two sides of the platymeter being equal to that of the one charged side, say  $p$ , before the connexion was made. But the surface of action is now equal to  $\left(1 + \frac{1}{n}\right) p$ , and the potential of the system, therefore, is now  $\left(\frac{1}{1 + \frac{1}{n}}\right) \times v$ , where  $v$  is the original potential of A and  $p$ . But the quantity of electricity taken from A and  $p$  is such as to raise B and  $p'$  to the same potential as that to which A and  $p$ , with which they are now connected, are reduced. But in condensers at equal potentials the capacities are proportional to the amounts of the charges. Suppose the original charge of A and  $p$  to be unity. Then their charge after distribution is  $\frac{1}{1 + \frac{1}{n}}$ , and that of B and  $p'$  is  $1 - \frac{1}{1 + \frac{1}{n}}$ . Then

$$A + p : B + p' :: \left(\frac{n}{n+1}\right) : \left(\frac{1}{n+1}\right) :: n : 1;$$

but

$$p : p' :: n : 1,$$

and therefore

$$A : B :: p : p'.$$

That is, generally, when there is no deflection, the condensers compared are to one another as the sides of the platymeter with which they are connected. But the reading obtained with the platymeter connexions arranged normally was greater than that obtained when they were reversed. The side  $p'$  is therefore greater than the side  $p$ .

Now let  $a$  be the greater and  $b$  the less reading with the value of the sliding condenser when its index is at zero added to them, and let  $x$  be the true value to be deduced from them. Then we have the ratios

$$p : p' :: x : a \text{ and } p' : p :: x : b,$$

therefore

$$x : a :: b : x, \text{ and } x = \sqrt{ab}.$$

That is, the true value of a condenser measured by an imperfect platymeter is the geometric mean of the two values obtained by the different arrangements of the connexions.

In practice, when the error of the platymeter is so small as it is in the present case, the arithmetic mean may be taken instead of the geometric. For let  $M$  be the arithmetic mean of  $a$  and  $b$ , and  $D$  the difference between it and either of these values. Then  $x = \sqrt{M^2 - D^2} = M \left(1 - \frac{D^2}{2M^2} - \frac{D^4}{8M^6} - \dots\right)$ . In the present case, where  $\frac{D^2}{2M^2}$  is about  $\frac{1}{25000}$ ,  $M$  does not differ sensibly from  $x$ . If  $\alpha$  be the greater and  $\beta$  the less reading, then  $z$ , the value (in scale-divisions) of the sliding condenser with its index at zero, is  $x - \frac{\alpha + \beta}{2}$ . When  $z$  has been determined, the true value of any condenser may be got by adding to it the mean of the two readings obtained; and when the error of the platy-

meter used has been once ascertained, this mean may be obtained from a single reading without reversing the connexions.

The following Table shows the values obtained for  $\alpha$  and  $\beta$  in the measurement of the spherical condenser:—

Date.	$\alpha$ .	$\beta$ .	$\frac{\alpha+\beta}{2}$ .
Nov. 17, 1869.....	211	183	197
Nov. 17, 1869.....	211	186	198.5
Nov. 19, 1869.....	211	.....	198

Taking 198 as the mean reading and 1572 as the value of  $x$ , the value of the sliding condenser with its index at zero was 1374 scale-divisions.

A condenser was now prepared having paraffine instead of air as the dielectric. This consisted of a flat circular brass box with a tube projecting from the centre of the lid, through which an electrode was carried from a brass disk imbedded in paraffine, with which the box and tube were filled, midway between the top and bottom of the box. The box was placed in water reaching nearly up to the top of the tube. For the value of this condenser at different temperatures the following results were obtained:—

Date.	Temp.	$\alpha$ .	$\beta$ .	$\frac{\alpha+\beta}{2}$ .	Value = $\frac{\alpha+\beta}{2} + x$ .
Nov. 17, 1869.....	11.5 C.	180	.....	168	1542
Nov. 18, 1869.....	13.3	215	192	203	1577
Nov. 18, 1869.....	17	.....	212	224	1598
Nov. 19, 1869.....	12.5	.....	220	232	1606
Nov. 19, 1869.....	15.8	228	206	217	1591
Nov. 22, 1869.....	17.9	235	.....	223	1597

Crevices which had formed in the paraffine when cooling, gradually admitted water so as ultimately to destroy the insulation of the disk.

The increase of capacity thus caused is probably sufficient to account for the variations shown in the Table, which, therefore, are not to be attributed to any alteration of inductive capacity due to change of temperature. Taking the first of the values, 1542 scale-divisions, or 63.687 centimetres, as probably the most accurate, the following determination of specific inductive capacity of paraffine is obtained. The value of the box condenser with air instead of paraffine as the dielectric, obtained from measurement of it on the sliding condenser described in the Appendix, is 32.306 centimetres. These two values give 1.975 as the specific inductive capacity of paraffine when that of air is taken as unity, a correction having been made on account of three vulcanite pins used to support the insulated plate.

The following form of condenser (see fig. 5) was next employed as being most likely to show effects of temperature undisturbed by other causes. Into a cylindrical brass vessel ( $a a$ ) 15.5 centimetres in depth and 8.61 centimetres in internal diameter, melted

paraffine was poured to a depth of about one centimetre. Upon this, when solid, a piece of brass tubing (*bb*), 4.3 centimetres long and 7.24 centimetres in internal, and 7.47 in external diameter, was rested so as to be concentric with the outer tube. Inside of this, and concentric with it, was placed another piece of brass tubing (*cc*), 13.1 centimetres long and 6.1 centimetres in external diameter. The space between this and the outer tube was then filled with paraffine, and from the middle tube thus imbedded a fine wire electrode (*dd*) was carried up. The condenser was put into a vessel containing water in which was placed a thermometer; and another thermometer (*ee*) was supported in the centre of the inner tube by a paraffine plug (*ff*) about a centimetre thick, which rested upon the top of this tube. This plug prevented the communication downwards of the temperature of the air. As an additional security, another paraffine plug (*gg*) of the same thickness was inserted in the inner tube a little above the bulb of the thermometer.

The outer and inner tubes were connected with the earth, and the electrode from the other tube, which was insulated, was connected with the one side of the platymeter.

An addition to the capacity of the sliding condenser had been made, increasing its zero-value, so that the readings for the spherical condenser were:

Date.	$\alpha$ .	$\beta$ .	$\frac{\alpha+\beta}{2}$ .
Dec. 13, 1869.....	28	2	15

This gives for the zero-value of the sliding condenser  $1572 - 15 = 1557$  scale-divisions.

With this value the results shown in the following Table were obtained for the value of the cylindrical paraffine condenser at different temperatures.

Date.	Temperature.			Condenser Scale.		Value.
	Outside.	Inside.	Mean.	$\alpha$ .	$\frac{\alpha+\beta}{2}$ .	
Dec. 22, 1869.....	7.5	7.5	7.5	158	145	1702
Dec. 22, 1869.....	17.6	17.6	17.6	158	145	1702
Dec. 29, 1869.....	2.7	2.7	2.7	150	137	1694
Dec. 30, 1869.....	5.7	5.7	5.7	147	134	1691
Dec. 30, 1869.....	15.4	15.7	15.55	145	132	1689

Without the addition to the value of the sliding condenser the following measurements of the spherical condenser were taken:—

Date.	$\alpha$ .	$\beta$ .	$\frac{\alpha+\beta}{2}$ .
Dec. 10, 1869.....	202	176	189
Jan. 5, 1870.....	201	.....	188
Jan. 7, 1870.....	200	.....	187
Jan. 8, 1870.....	199	.....	186
Jan. 12, 1870.....	201	.....	188
Jan. 17, 1870.....	202	.....	189
Jan. 17, 1870.....	202	173	187

These readings give the zero value  $=1572-188=1384$ . With this value of  $z$  the following measurements of the cylindrical paraffine condenser were obtained:—

Date.	Temperature.			Condenser Scale.		Value.
	Outside.	Inside.	Mean.	$\alpha$ .	$\frac{\alpha+\beta}{2}$ .	
Jan. 6, 1870 .....	.....	13°	.....	322	309	1693
Jan. 6, 1870 .....	10	10·7	10·35	316	303	1687
Jan. 6, 1870 .....	26·2	13·4	19·8	314	301	1685
Jan. 7, 1870 .....	21·2	20·5	20·85	318	305	1689
Jan. 8, 1870 .....	8·2	8·2	8·2	322	309	1693
Jan. 8, 1870 .....	17·7	14·9	16·3	319	306	1690
Jan. 8, 1870 .....	16·4	16·2	16·3	319	306	1690
Jan. 11, 1870 .....	7·1	7·1	7·1	320	307	1691
Jan. 12, 1870 .....	24·7	24	24·35	316	303	1687
Jan. 12, 1870 .....	23	24·3	23·65	317	304	1688

In order to vary the conditions of the experiment so as to allow the paraffine to expand more freely, a condenser of the following form was employed. Its metallic surfaces consisted of circular pieces of tinfoil. These were arranged horizontally with plates of paraffine half a centimetre thick between them. The following Table shows the values obtained for this condenser at various temperatures, the zero-value of the sliding condenser being still the same:—

Date.	Temp.	Condenser Scale.		Value.
		$\alpha$ .	$\frac{\alpha+\beta}{2}$ .	
Jan. 18, 1870 .....	11·4	269	256	1640
Jan. 18, 1870 .....	21·8	263	250	1634
Jan. 19, 1870 .....	14·5	267	254	1638
Jan. 25, 1870 .....	7·2	271	258	1642

These values arranged according to temperature are as follows:—

Temp.	Value.
7·2	1642
11·4	1640
14·5	1638
21·8	1634

Some experiments were now made upon the expansion of paraffine with temperature, with a view to determine the alterations produced by it in the capacity of paraffine condensers. This was done by weighing a quantity of paraffine in thin plates, with a platinum sinker attached, in distilled water at different temperatures. The weight of the paraffine in air was 48·358 grammes, that of the platinum was 8·625 grammes, or



altogether 56·983 grammes. The following Table shows the results of the weighings in water. The weights are given in grammes, and the volumes in cubic centimetres.

Temperature.	Weight of paraffine and platinum in water.	Weight of water displaced by both.	Volume of both.	Volume of platinum.	Volume of paraffine.
1	3·698	53·285	53·289	·4077	52·881
8·8	3·413	53·570	53·579	·4078	53·171
10·1	3·372	53·611	53·626	·4078	53·218
17·2	3·139	53·844	53·909	·4079	53·501

These numbers give for the expansion of paraffine the results shown in the following Table\* :—

Temperature.			Difference of volume.	Mean volume.	Total expansion.	Cubic expansion per degree.	Linear expansion per degree.	Mean temperature.
From	To	Diff.						
1	8·8	7·8	·290	53·026	·00547	·000701	·000234	4·9
1	10·1	9·1	·337	53·049	·00635	·000698	·000233	5·55
1	17·2	16·2	·620	53·191	·01166	·000720	·000240	9·1
8·8	10·1	1·3	·047	53·195	·00088	·000677	·000226	9·45
8·8	17·2	8·4	·330	53·336	·00619	·000737	·000246	13
10·1	17·2	7·1	·283	53·360	·00530	·000746	·000249	13·65

From these determinations of the expansion of paraffine the effect produced by variations of temperature upon the capacity of the tinfoil condenser may be easily calculated. The mean value of the condenser 1638·5 scale-divisions may be taken as its value at the mean temperature 13°·7. Its values at the different temperatures estimated from this, together with those previously given as obtained from actual measurements, are shown in the following Table :—

Temperature.	Measured value.	Estimated value.
7·2	1642	1641
11·4	1640	1639·4
14·5	1638	1638·2
21·8	1634	1635·1

The values given in the last column of this Table were estimated on the supposition that the expansion of the paraffine did not produce any sensible stretching of the tinfoil; and this, from the manner in which the condenser was formed, was probably the case. From this it appears that the regular alteration in the values obtained for this condenser at different temperatures follows so nearly that resulting from the variations of the

\* After these experiments were made it was found that the French "Bureau des Longitudes," in the 'Annuaire' for 1870 published by them, give, on the authority of M. FIZEAU, ·00027854 per degree Centigrade as the coefficient at 40° Centigrade of linear expansion of "paraffine de Rangoon," and ·0000009926 as the "variation of coefficient" per degree. This gives ·00024787 as the expansion per degree at temperature 9°·1, that given in the Table at the same temperature being ·000240.

distance between the plates due to the expansion of the paraffine that no change of specific inductive capacity can be inferred from it.

The following further measurements of the Cylindrical Paraffine Condenser were now made, the zero-value of the sliding condenser being still equal to 1384 scale-divisions.

Date.	Temperature.			Condenser Scale.			Value.
	Outside.	Inside.	Mean.	$\alpha$ .	$\beta$ .	$\frac{\alpha+\beta}{2}$ .	
Feb. 10, 1870.....	-17.8	-6.4	-12.1	.....	282	294	1678
Feb. 11, 1870.....	.....	-0.2	.....	.....	280	292	1676
Feb. 15, 1870.....	5.4	4.85	5.125	307	.....	295	1679
Feb. 15, 1870.....	-15.4	-4.65	-10.025	306	.....	294	1678
Feb. 15, 1870.....	-14.1	-10.2	-12.15	305	.....	293	1677
Feb. 15, 1870.....	-11.5	-11.25	-11.375	.....	285	297	1681
Feb. 15, 1870.....	-10.25	-11.125	-10.79	310	.....	298	1682
Feb. 16, 1870.....	0.5	0.425	0.46	309	.....	297	1681
Feb. 17, 1870.....	5.2	4.37	4.78	.....	285	297	1681
Feb. 18, 1870.....	6.5	5.8	6.15	.....	284	296	1680
Feb. 18, 1870.....	6.5	5.8	6.15	308	.....	296	1680
Feb. 18, 1870.....	16.6	10.8	13.7	305	.....	293	1677
Feb. 23, 1870.....	18.7	18.45	18.57	302	.....	290	1674
April 6, 1870.....	.....	.....	12.6	309	.....	297	1681

All the values obtained for this condenser at different temperatures are shown in the following Table arranged in the order of temperature:—

Date.	Temperature.	Value.
Feb. 15, 1870 .....	-12.15	1677
Feb. 10, 1870 .....	-12.1	1678
Feb. 15, 1870 .....	-11.375	1681
Feb. 15, 1870 .....	-10.79	1682
Feb. 15, 1870 .....	-10.025	1678
Feb. 11, 1870 .....	-0.2	1676
Feb. 16, 1870 .....	0.46	1681
Dec. 29, 1869 .....	2.7	1694
Feb. 17, 1870 .....	4.78	1681
Feb. 15, 1870 .....	5.125	1679
Dec. 30, 1869 .....	5.7	1691
Feb. 18, 1870 .....	6.15	1680
Feb. 18, 1870 .....	6.15	1680
Jan. 11, 1870 .....	7.1	1691
Dec. 22, 1869 .....	7.5	1702
Jan. 8, 1870 .....	8.2	1693
Jan. 6, 1870 .....	10.35	1687
April 6, 1870 .....	12.6	1681
Jan. 6, 1870 .....	13	1693
Feb. 18, 1870 .....	13.7	1677
Dec. 30, 1869 .....	15.55	1689
Jan. 8, 1870 .....	16.3	1690
Jan. 8, 1870 .....	16.3	1690
Dec. 22, 1869 .....	17.6	1702
Feb. 23, 1870 .....	18.57	1674
Jan. 6, 1870 .....	19.8	1685
Jan. 7, 1870 .....	20.85	1689
Jan. 12, 1870 .....	23.65	1688
Jan. 12, 1870 .....	24.35	1687

The differences of these values show no alteration of specific inductive capacity of paraffine due to variations of temperature.

The absolute value of this condenser with air as the dielectric, obtained by measurement of it on the sliding condenser described in the Appendix, is 35.394 centimetres; and taking the mean of these values with paraffine, 1684 scale-divisions, or 69.552 centimetres, the specific inductive capacity of paraffine is found to be 1.965, that of air being taken as unity. The layer of paraffine under the insulated tube had been left in for the purpose of supporting it. The correction necessary on account of this increases this number to 1.977.

#### APPENDIX.

The sliding condenser described in this paper was found to be too limited in range, and liable to failure of insulation owing to the admission of shreds. Another sliding condenser (referred to at pages 576, 578, and 583) was therefore employed of such a construction as to give greater range and more perfect insulation. The tubes of this instrument were arranged vertically, and were supported by a wide brass cylinder surrounding the insulated tube at a considerable distance from it, and secured to a massive upright iron support. To a brass disk forming the cover of this cylinder the insulated tube was fastened by a vulcanite collar, into which it was screwed, so as to hang vertically in the middle of the surrounding cylinder. This cover also supported the uninsulated tube directly above the insulated tube so as to be coaxial with it. The core, instead of sliding upon feet as in the instrument formerly described, moved in two V supports cut in the brass plates which closed the ends of the uninsulated tube. The points of support and the springs which press the moving core against them are formed by cutting the brass plates in the manner shown in the annexed figure. Another tube, about 7 millimetres greater in diameter than the insulated tube, was supported by the plate closing the lower end of the wide brass cylinder so as to slide vertically round the insulated tube. By altering the position of the core and of this outer tube, which was uninsulated, the value of the condenser could be so varied that capacities ranging from 47 to 180 centimetres could be measured upon it. The position of the outer tube and that of the core were indicated upon scales of  $\frac{1}{40}$  of an inch engraved upon the tubes themselves.

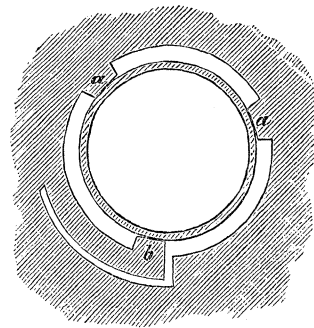

*a, a.* Points of support.  
*b.* Spring.

Fig. 1.

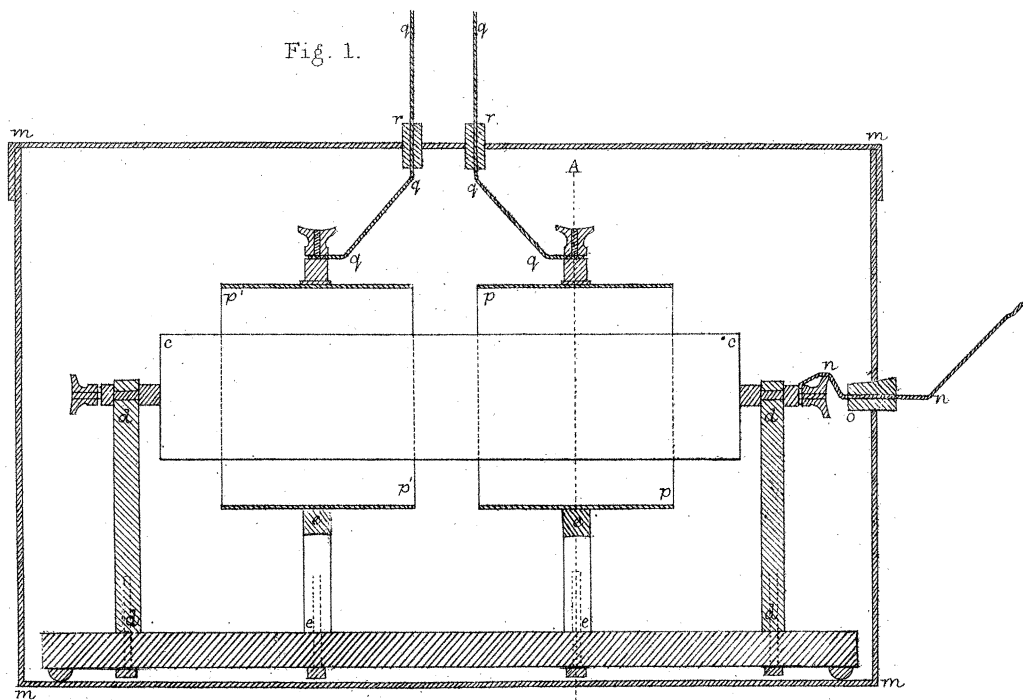

Longitudinal Section of Platymeter.  $\frac{1}{3}$  Size.

Fig. 1.

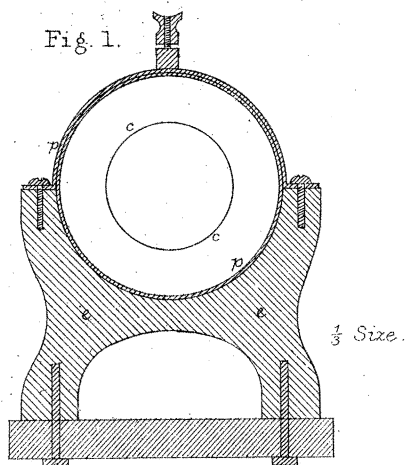

Section through A.B.

Fig. 2.

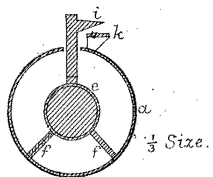

Section through C.D.

Fig. 2.

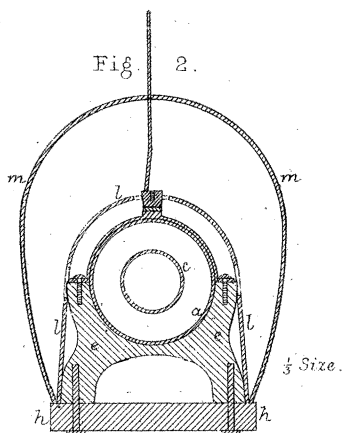

Section through A.B.

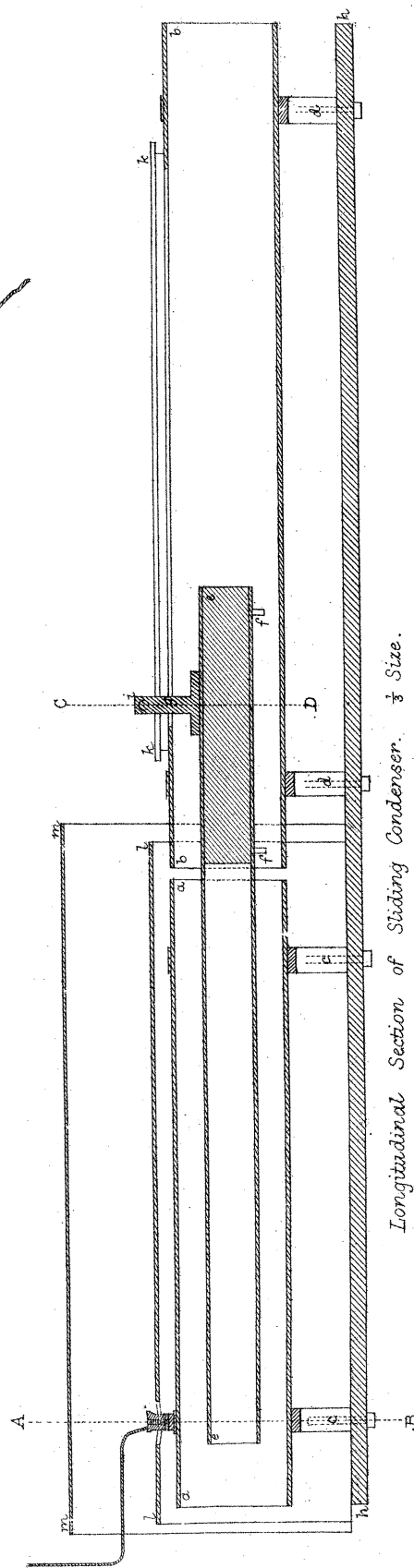

Longitudinal Section of Sliding Condenser.  $\frac{1}{3}$  Size.

Fig. 3

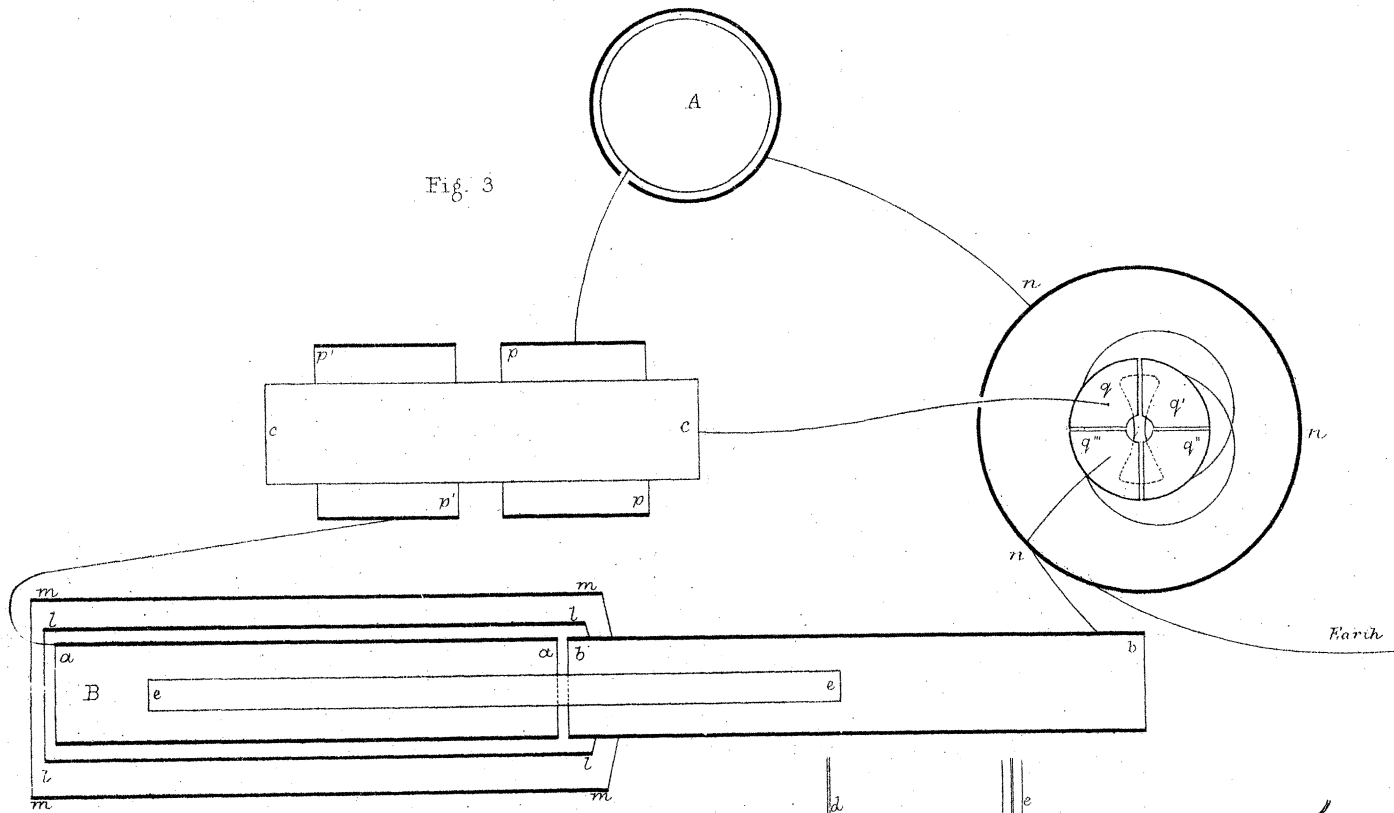

Sectional Plan showing Connections:  $\frac{1}{4}$  Size.

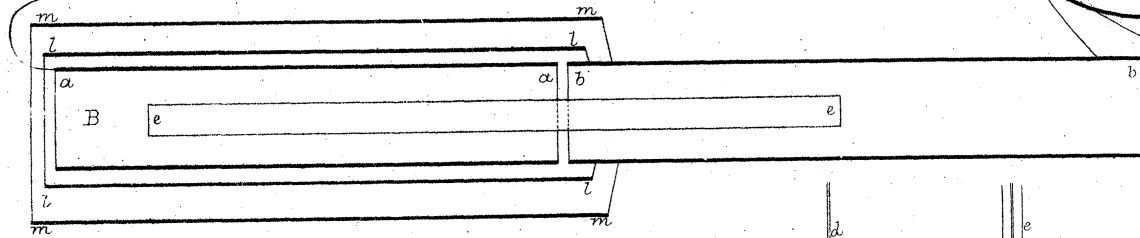
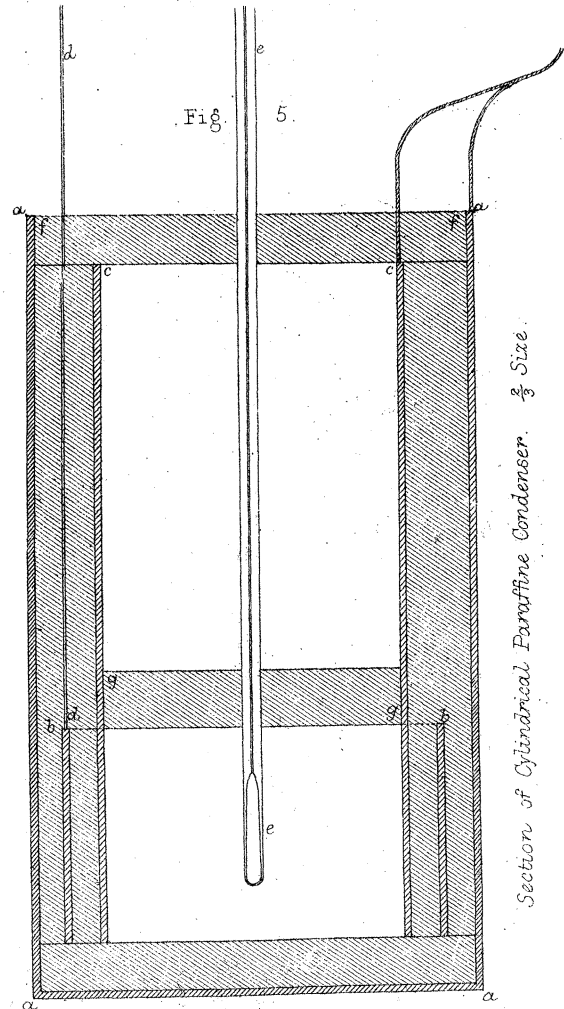
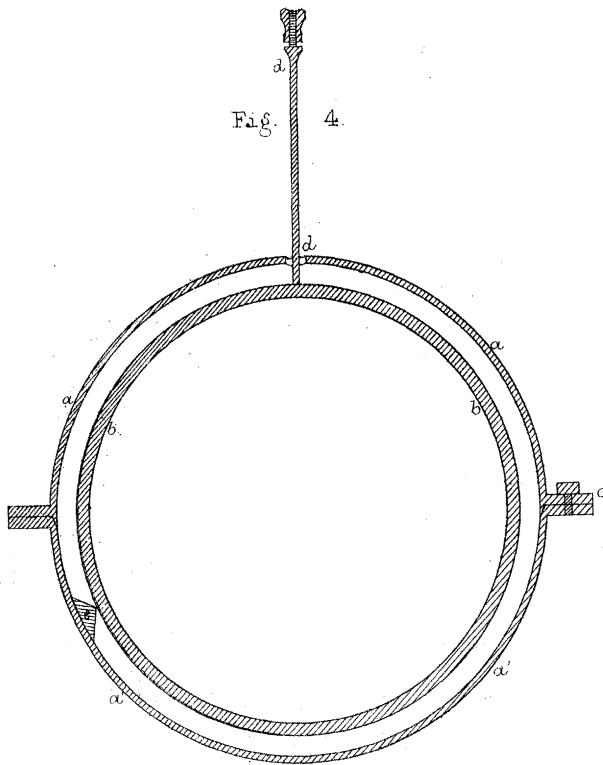

Fig. 5



Section of Cylindrical Paraffine Condenser.  $\frac{2}{3}$  Size.

Fig. 4



Section of Spherical Condenser.  $\frac{2}{3}$  Size.